



***Envirograf***<sup>®</sup>  
FIRE PREVENTION PRODUCTS



---

# Motorised Fire & Smoke Curtain

---

Product 90: Traditional (Old-Style) Curtain  
Product 90/1: New-Style Curtain

# PRODUCT MANUAL

**PLEASE KEEP THIS IN A SAFE PLACE**

Issue date 11 June 2012

---

INTUMESCENT SYSTEMS Ltd.  
Envirograf House, Barfrestone, Dover, Kent, CT15 7JG  
Tel: 01304 842555 Fax: 01304 842666

# **INDEX**

## PAGE NUMBER

INTRODUCTION.....	3
OPERATION.....	3
NEW STYLE CURTAIN INFORMATION.....	4
NEW STYLE CURTAIN FIXING DETAIL.....	5
TRADITIONAL STYLE CURTAIN INFORMATION.....	8
TRADITIONAL STYLE CURTAIN FIXING DETAIL.....	9
GENERAL WIRING INFORMATION.....	11
AUTO 2 CONTROL PANEL WIRING.....	12
USING THE CURTAIN .....	13
AFTERCARE MAINTENANCE.....	13
SERVICE CONTRACT.....	13
SERVICE CONTRACT - TERMS & CONDITIONS.....	14
MAINTENANCE & REPAIRS INFORMATION.....	15

## **INTRODUCTION**

For many years, Envirograf® have been a market leader in Passive Fire Prevention, including Fire and Smoke Curtains. Envirograf® now only manufacture Motorised Fire & Smoke Curtains and there are two types available;

The New Style - 24 volt DC Motorised System and the Traditional Style - 24 volt DC Motorised System; both can be activated by a Fire Alarm System, Smoke or Heat Detection, or a combination.

## **OPERATION**

Both Curtains can be controlled by an Envirograf® Control Unit (Auto 2 for the New Style and Auto 3 for the Traditional Style), which requires a 240 volt AC supply. The Control Unit has connectors for independent Smoke or Heat Detectors, our Type 65. It also has a pair of Normally Closed Contacts to connect to into any existing Fire Alarm System.

The Control Panel measurements are: 410 mm wide x 283 mm high x 100 mm deep (Auto 2)  
310 mm wide x 310 mm high x 220 mm deep (Auto 3)

Both the New Style and Traditional Style Curtains have a Control Unit supplied with the Curtain Unit, these have a 24 volt back up battery, and can be connected to the fire alarm system with a N/C volt free contact.

For both Curtains, a manual override test switch, which is located on the front of the Control Unit, allows 'up and down' operation of the Curtain for test, service and maintenance purposes; this does not activate the Fire Alarm System. In addition, an independent localised test switch can be integrated into the system for ease of use or day-to-day operation. This enables the Control Unit to be located out of sight, ie. in a roof void, etc.

In normal working conditions, the Curtain is fully raised. When the Fire Alarm or Detection method is activated, the Curtain will lower down to the closed position. When the Alarm or Detector is reset, the Curtain will return back to the open position.



TRADITIONAL (OLD) STYLE CURTAIN



NEW STYLE CURTAIN

## **NEW STYLE CURTAIN**

An easy to install Curtain for both recessed and surface mounted; to fit openings up to;

600 mm wide x 1800 mm high / 1700 mm wide x 1500 mm high

All metalwork is powder coated brown, white and black as standard; other BS or RAL colours can be quoted upon request. The Curtain material is supplied in grey.

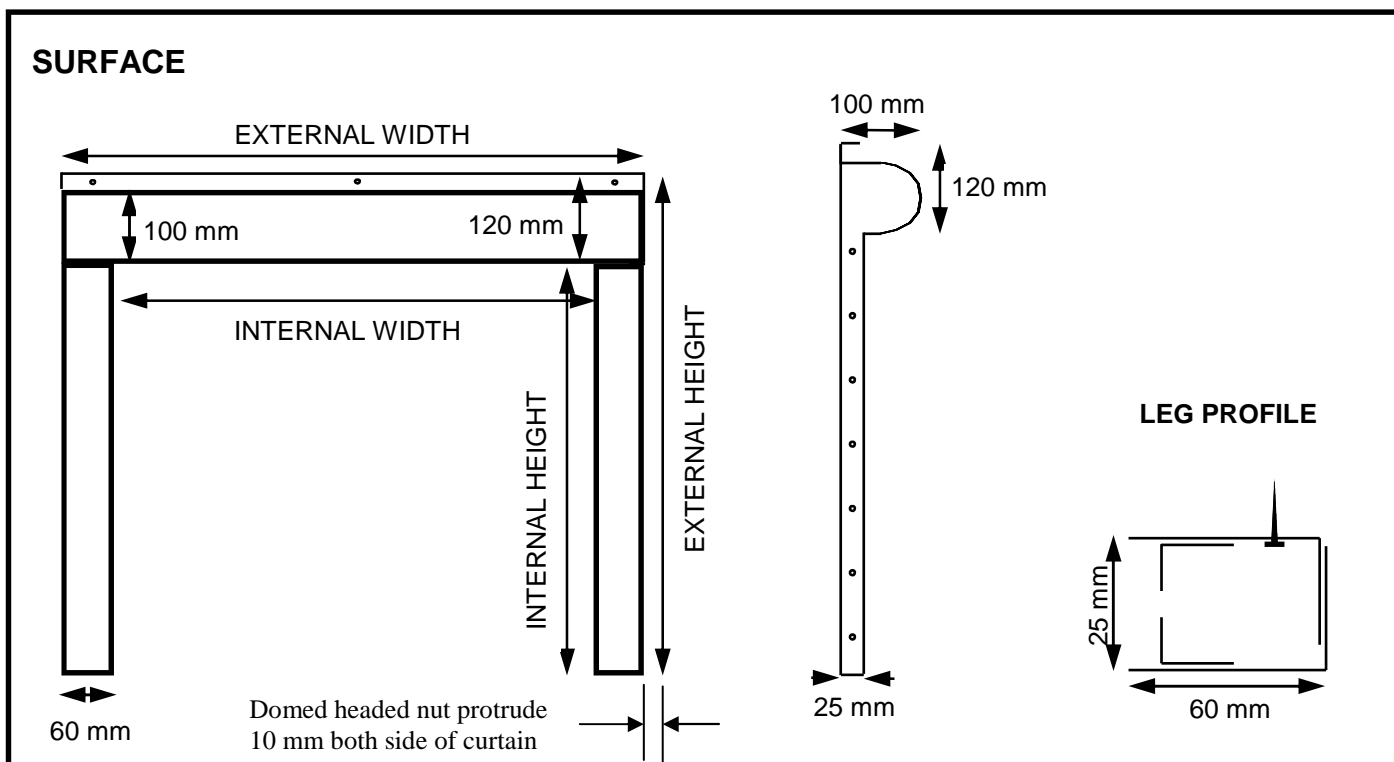
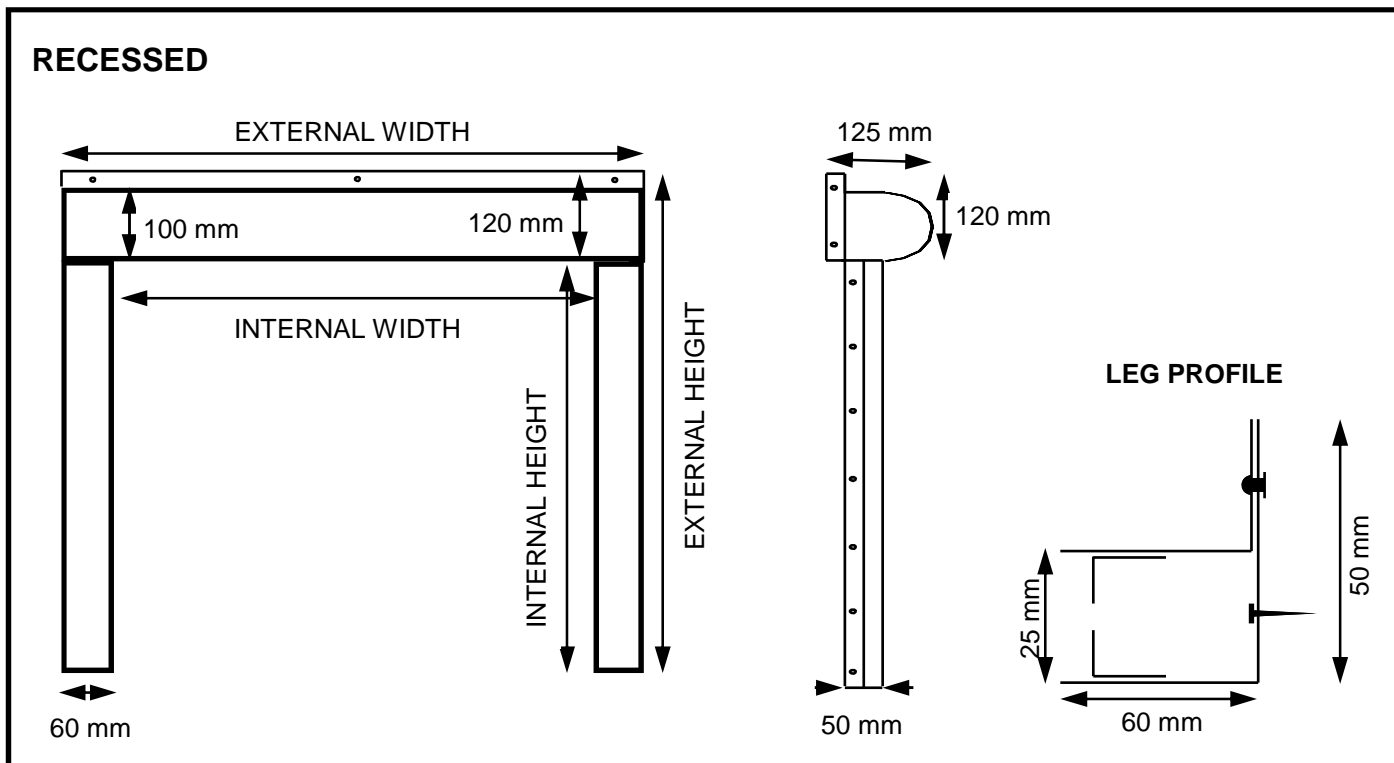

### STEP ONE

Unpack the curtain and check that all the parts are there and no damage has accrued during transit. Any missing or damaged parts must be reported within three days of delivery.

#### Parts List

- Motor Housing

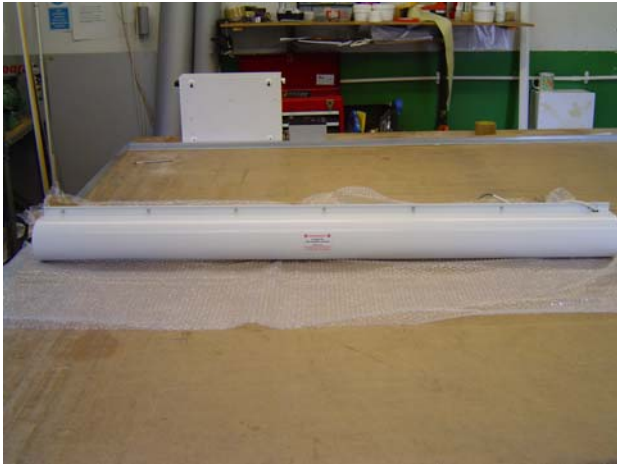

- Legs x 2



- Control Panel



### STEP TWO

Remove lid to motor housing and place nuts and washers in a safe place.

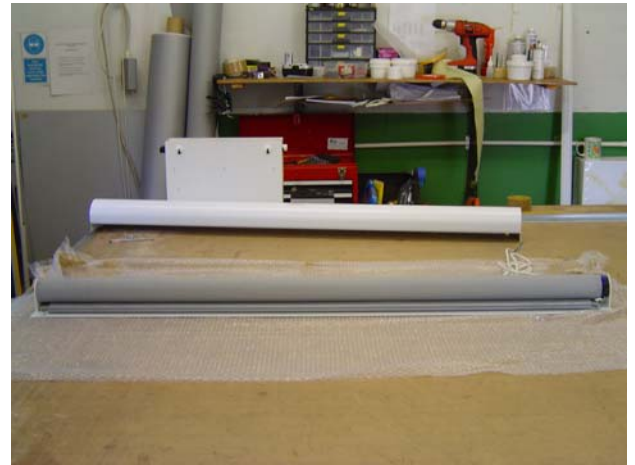

Remove the front section of the legs, leave front of legs in a safe place.



Remove the lock nuts in bottom corners of Motor housing and attach the top of the leg to housing.



### STEP THREE

Once legs and housing are attached offer the frame to the hole and making sure the curtain is level mark where the fixings holes are to be.



Using the correct fixing for the building fabric fix frame to the wall.



### STEP FOUR

Run a bead of intumestant mastic around the frame on both inside and outside.



Take front sections of the legs and fit to back section. Leaving a gap of approximately 1 and 2mm between front and back.

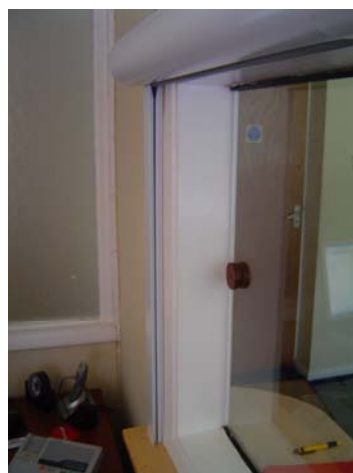

## STEP FIVE

Choose a suitable location preferable next to or just above the curtain frame. Fix the panel to the wall and using either the wiring diagram in side this manual (page 12) or in the panel its self connect to the curtain, fire alarm and fused spur. Please note that a qualified electrician should carry out all electrical works.



Once connection is complete turn on fuse spur and using the key on the side of the panel test the operation of the curtain.

NOTE if there is no signal from the fire alarm then a link can be connected between terminals 3 and 6 but this **MUST** only be used for testing purposes.



## STEP SIX

Once happy with the operation of the curtain replace the lid of the housing and then contact Envirograf on +44(0) 1304 842555 to arrange for a trained engineer to commission the curtain so that a fire certificate can be issued.

## **TRADITIONAL STYLE CURTAIN**

An easy to install Curtain for both recessed and surface mounted; to fit openings up to;

6000 mm wide x 3000 mm high (please telephone prior to order)

The top motor housing and legs are powder coated brown, white and black as standard; other BS or RAL colours can be quoted upon request. The Curtain material is supplied in grey.

### **RECESSED**

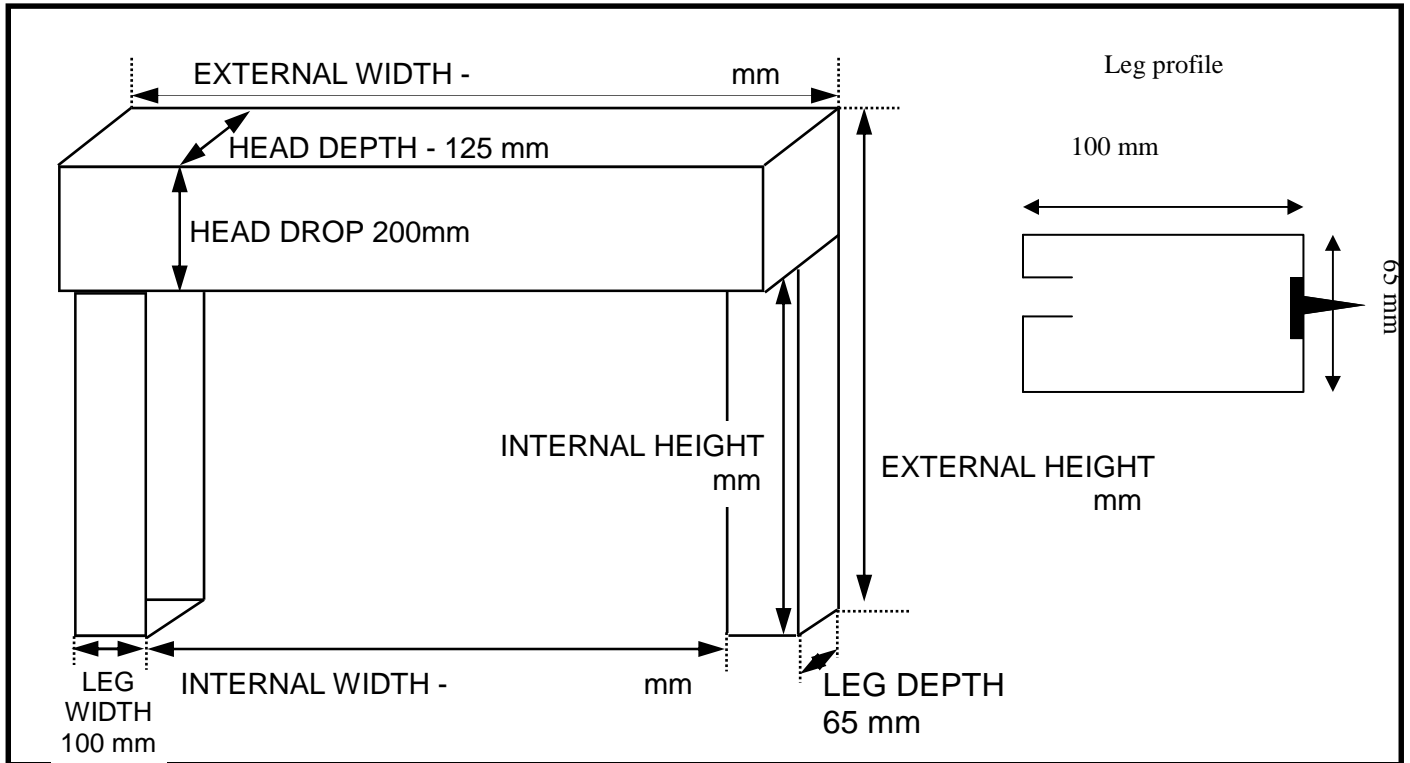

### **SURFACE**

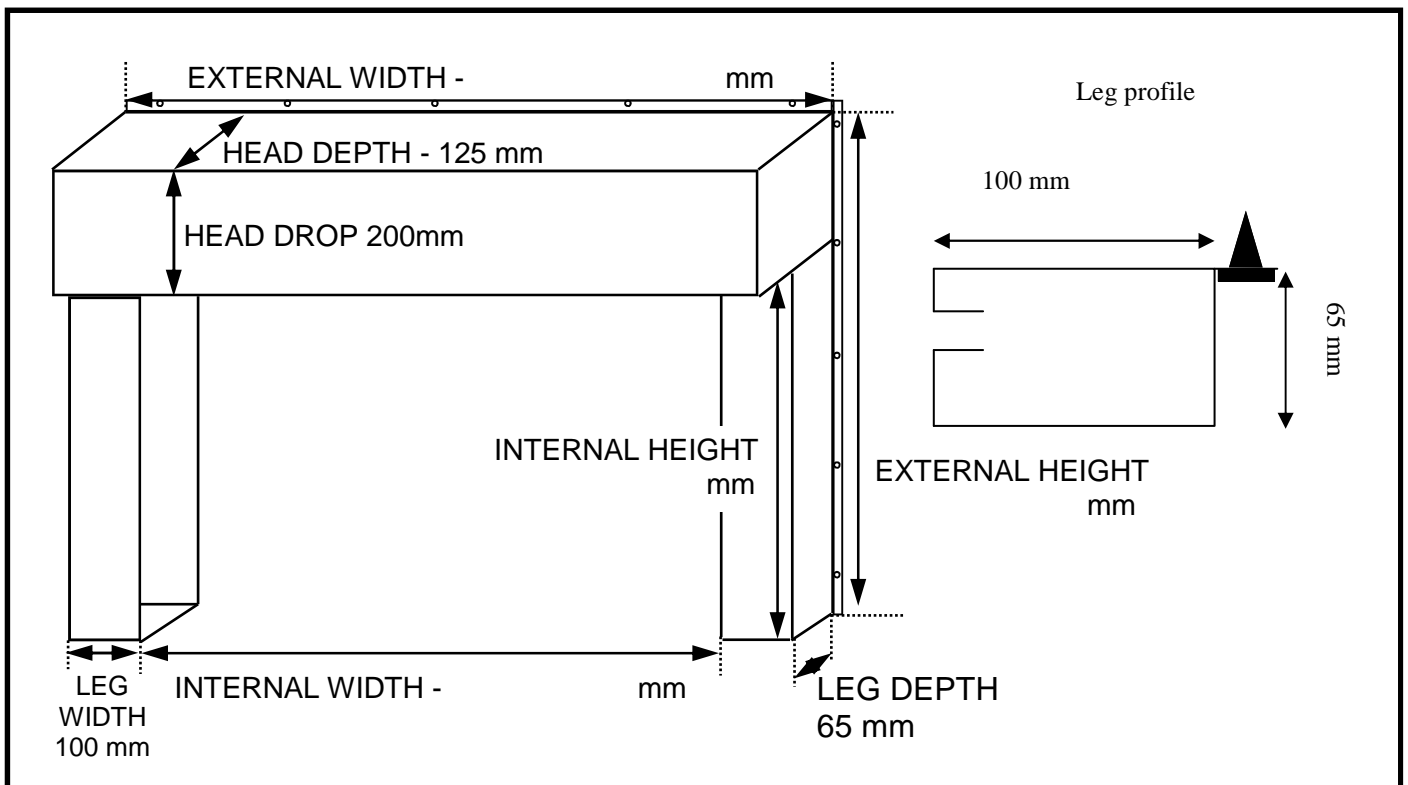



### STEP ONE

Unpack the curtain and check that all the parts are there and no damage has accrued during transit. Any missing or damaged parts must be reported within three days of delivery.

#### Parts List

- Motor Housing



- Legs x 2



- Control Panel



### STEP TWO

Remove one side of the brush holder on each leg.



Using the M6 screws provided attach the legs to the motor housing.



Offer the frame up to the hole and mark where the fixings are to be.



### STEP THREE

Using the correct fixings for the building fabric fix the frame to the wall. Making sure the frame is level.



Once the frame is fixed to the wall replace the brush holder on each leg.



### STEP FOUR

Run a bead of intumestant mastic around the frame on both inside and outside.



### STEP FIVE

Choose a suitable location for the control panel, preferable next to or just above the frame.



**NOTE.** Due to the complexity of the control panel it is advised that a trained Envirograf engineer comes to connect to the fused spur and the curtain to the control panel, at the same time they can commission the curtain and issue a fire certificate.

## GENERAL WIRING INFORMATION

IMPORTANT - THIS MUST BE INSTALLED BY A QUALIFIED ELECTRICIAN

The information given below only shows the location of items that can / must be used in conjunction with the Curtain.

Detail wiring diagrams are available; these are inside the Control Unit.

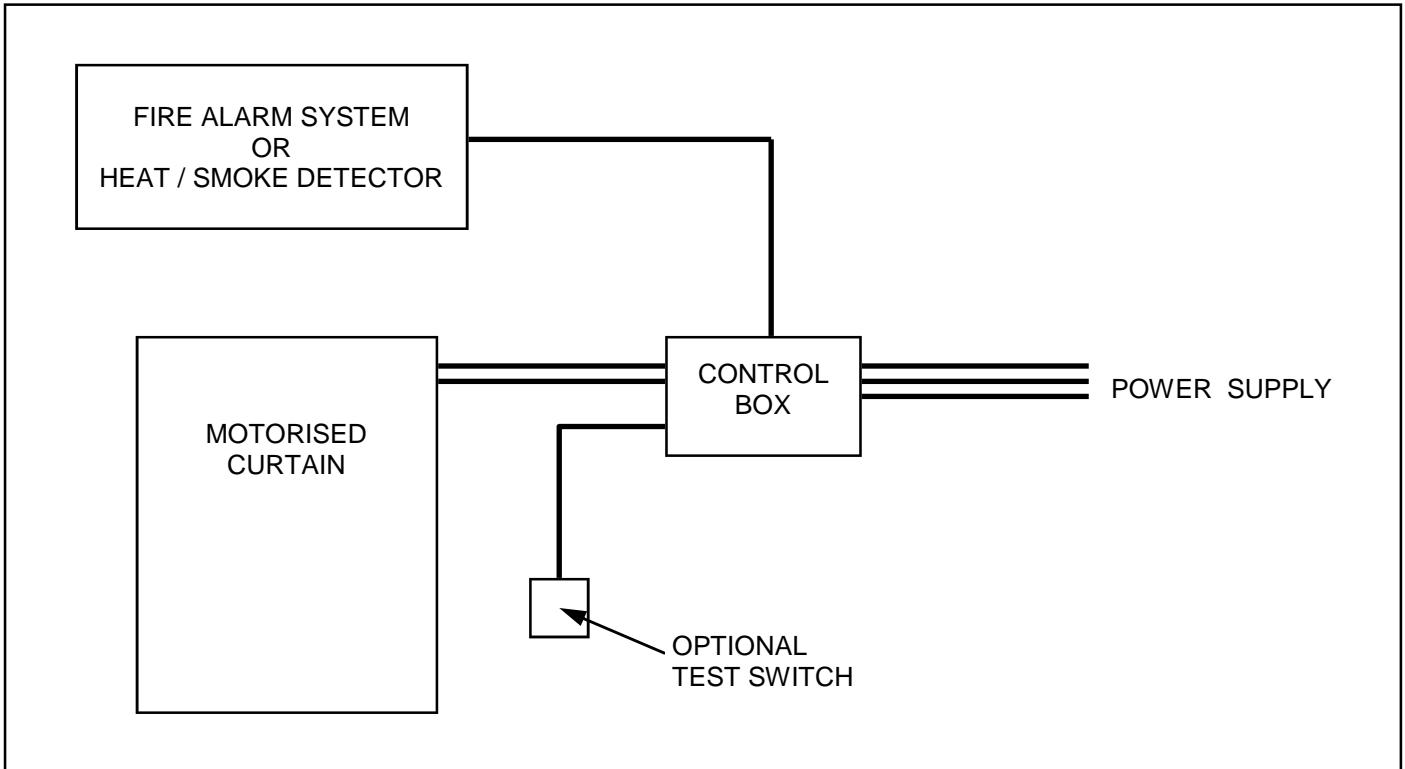

# Connecting the Envirograf® AUT02 Control Panel

## Left hand PCB connections

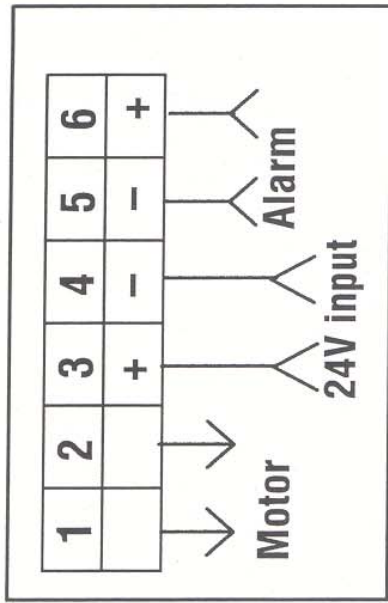

## Using 24V

from alarm

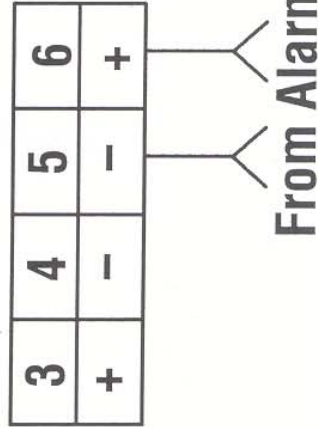

## Using Type

65 Detector



## Using normally-closed contact from alarm

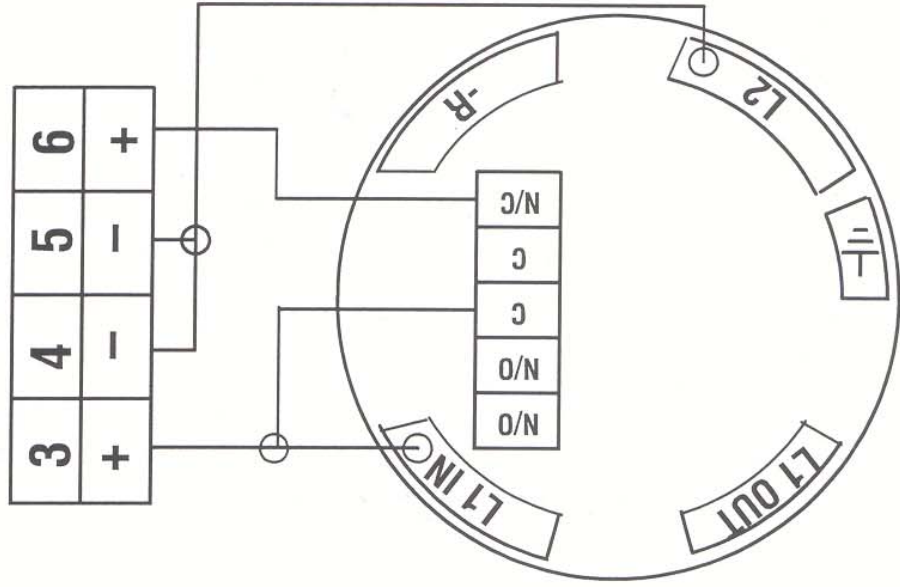
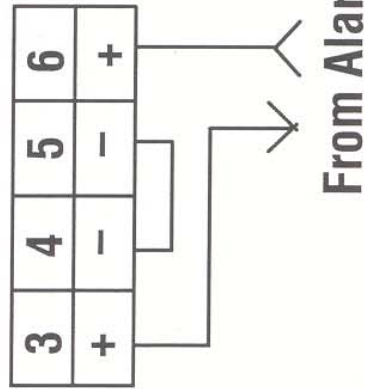

## CONNECT 240V AC TO MAINS TERMINALS

Revised 1st April 2005

## **USING THE ENVIROGRAF CURTAIN**

The Envirograf Motorised Fire and Smoke Curtain will work automatically with the fire alarm system. When the alarm is activated the curtain will lower to the closed position and once the alarm is reset the curtain will go back to the open position, this is completely automatic.

There is a test switch on the side of the control panel which will lower and raise the curtain without activating the fire alarm system.

## **AFTER-CARE / MAINTENANCE**

Once the Curtain has been installed and everything is in working order, we will send our Engineer to site to commission the Curtain. Once we have his confirmation, we will issue you with a Certificate of Guarantee. This will also be sent if we install the Curtain.

General hygiene procedures must be followed, such as regular dusting and cleaning of the unit. Do not use any water or detergents on the unit. You may use a very damp cloth if required.

Visually check the Curtain, ensuring that the material guides in the legs are clear.

Any electrical problems must be dealt with by a Qualified Electrician or ourselves. This is covered by the Guarantee for first 12 months, but thereafter, you will require an Annual Maintenance Contract in order to receive a certificate of compliance for Fire Safety. This is not normally covered by your fire alarm company and without it your insurance may be void. We recommend that you take advantage of Maintenance / Service Contract, details of which are below.

## **SERVICE CONTRACT**

Under current legislation the 'RRO The Regulatory Reform (Fire Safety) Order 2005 require that all fire safety measures are checked regularly and managed by a responsible person with the necessary knowledge, training and experience.

To support this Envirograf provide service agreement which will include :

- An Annual visit to check correct and efficient operation/cleaning of curtains;
- Clean / Lubricate and adjust where necessary;
- Where identified, advice on the need for replacement parts and damage to the product;
- On completion the engineer will issue a report of their findings, work carried out and any recommendations. They will also arrange for a certificate to be issued, stating that the curtain is working correctly; you should present this to the Fire Officer when you have a Fire check; arrange for a certificate to be issued, stating that the curtain is working correctly; you should present this to the Fire Officer when you have a fire check;
- If you have a problem with the curtain throughout the service contract period, your contract includes all necessary visits from an Engineer to resolve the problem or advise on the repair / parts required;
- Any damage, be it accidental or not is not covered;
- Replacement parts and materials are not covered.

This service includes all labour costs including all travelling expenses, if the fault is due to normal wear and tear; all replacement parts are chargeable and will come with a full twelve months guarantee.

Some of our customers prefer us to visit their Curtain monthly to check its operation. This is the favoured Contract for sites with multiple Curtains.

Envirograf are able to tailor the contract to suit your specific requirement and can quote accordingly.

Please telephone 01304 842555, if you require further information.

## **SERVICE CONTRACT - TERMS AND CONDITIONS**

1. During each annual period of this contract, the equipment covered by the contract will receive a full services at a frequency set out. "FULL SERVICE" means the cleaning and adjusting of the equipment to ensure its correct operation. Replacement Parts and Damage are not covered and will therefore be charged separately. All replacement parts are supported with a full twelve months warrantee.
2. In the event of being notified by the customer of any malfunction of the equipment, the company will at no extra cost to the customer, providing malfunction is not caused by misuse of the equipment, within 48 hours of such notification, provide either telephone or on site assistance to remedy such malfunction, unless weather conditions dictate otherwise.
3. No liability can be accepted for the inspection or servicing of any equipment not made available at the time of the scheduled visit, nor will any liability be accepted for any indirect or consequential loss or damage, however caused, or for loss or damage caused or contributed to, by the operation or failure to operate of any equipment to which this contract relates. The total liability of the company for any loss of the customer in any one-year of this contract shall not exceed the company's charges for providing the full service in any given annual period.
4. The customer is advised that adequate insurance is always essential. Our liability is limited to our obligation to carry out this contract in accordance with its terms and to any liability we might have for personal injury or death caused by the act or neglect of employees or ourselves or for such other loss or damage caused by such an act or neglect.
5. The customer will be supplied with a certificate of service after each full service visit.
6. The customer will be notified prior to each contract period as to the charges. These will be held firm for a period of three months, but there after may be charged subject to written notice to the customer. When the customer has been given notice of an increase they may within one month by notice in writing to the company elect to determine this contract upon expiry of the companies' notice of increase.
7. The contract shall be deemed to have commenced at the date on which it was initially made between the company and the customer and shall continue for a fixed period of twelve months and shall, unless terminated under clause 8 below, automatically be renewed for a further twelve-month period.
8. Subject as aforesaid this contract shall be determinable by either party upon three months' notice in writing to the other. In absence of such notice, the company shall be reimbursed for any abortive visit made by one of the representatives.
9. The company reserves the right to terminate this contract at any time with or without notice, should the customer fail to comply with any of its provisions, commits an act of bankruptcy or has a receiver appointed for the purpose of winding up the business.
10. The customer shall:
  - a. Use the equipment only in accordance with instructions and recommendations relating to its care and operation provided by the company.
  - b. Not allow any person other than a representative of the company to adjust, maintain, repair, replace or remove any part of the equipment without notice in writing to the company.
  - c. Take all steps as may be necessary to ensure the safety of a representative of the company who visits the customers' premises.
11. Payment by the customer will be due upon receipt of the company's invoice and should be made direct to the company within 30 days of the invoice.
12. The schedule forms part of this contract.
13. Nothing in this contract shall affect the statutory rights of the customer.
14. The contract is subject to the laws of England.

